

RoHS

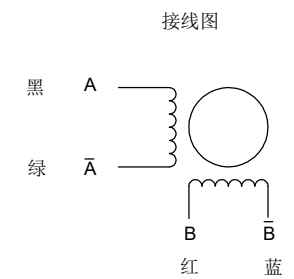
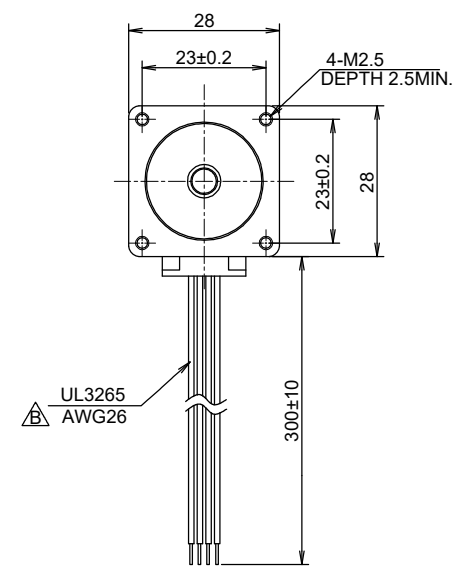
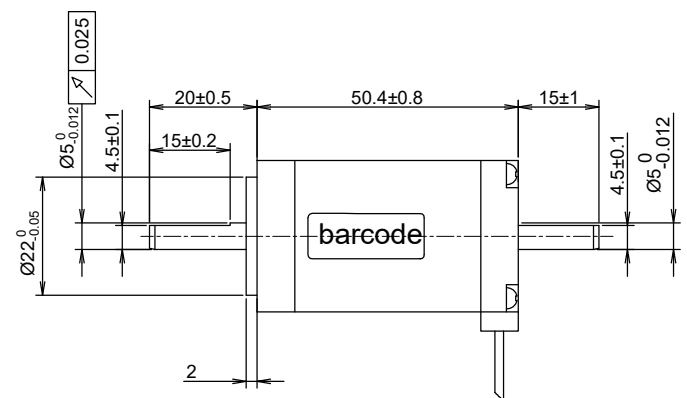
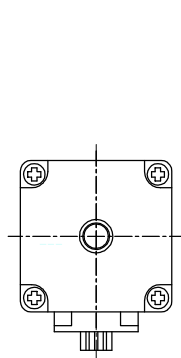

励磁顺序 (两相励磁) VS 旋转方向

STEP	A	B	Ā	B̄	
1	+	+	-	-	CW
2	-	+	+	-	
3	-	-	+	+	
4	+	-	-	+	CW

从电机安装面看为顺时针

YYWWXXXXX

Stator barcode label

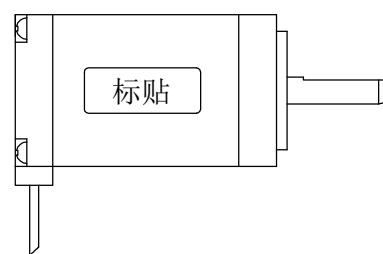

注 黑色端盖

电机参数	
步进角	1.8°±5%
额定电流	1.0 Amps/PHASE
保持力矩	0.14 N.m MIN.
电阻	2.5 ohm±10% AT 25°C
电感	2.2 mH±20% AT 1kHz, 1Vrms
转子惯量	20g.cm ²
绝缘等级	CLASS B
绝缘耐压	500V A.C 1MINUTE
防护等级	IP 20
重量	200g
温升	80K MAX.
额定运行环境温度	-20°C---+50°C
允许轴向负载	10N
允许径向负载	21N (ON THE SHAFT END)

电机型号
EW11-310D
步进电机规格书

单位: mm
未标注长度及角度默认公差
长度: ±0.3mm 角度: ±5%
电机检验标准: QC-ZL-011

版本	日期	描述	出图人
B	24-05-21	线规修正	BUD
A	06-03-21	first version	BUD



APPROVED
John